

6500/7500 SERIES

OWNERS OPERATION GUIDE

104°



HYDROQUIP™

CONTENTS

Important Safety Instructions	2
--	----------

Introduction	4
---------------------------	----------

FEATURES & FUNCTION

Ground Fault Circuit Interrupter (GFCI)	5
--	----------

Heater “On” Indicator	5
------------------------------------	----------

Spaside Control	6
------------------------------	----------

Setting Filtration	8
---------------------------------	----------

Error Identification	9
-----------------------------------	----------

OPERATIONAL CONSIDERATIONS

Warm Weather Conditions	10
--------------------------------------	-----------

Filtration	11
-------------------------	-----------

Freeze Protection & Winterizing	11
--	-----------

Chemical Water Treatment	11
---------------------------------------	-----------

TROUBLESHOOTING	12
------------------------------	-----------

Warranty Information	15
-----------------------------------	-----------

Notes	16
--------------------	-----------

IMPORTANT SAFETY INSTRUCTIONS

READ AND FOLLOW ALL INSTRUCTIONS

- ! **DANGER** To reduce the risk of injury, do not permit children to use this product unless they are closely supervised at all times.
- ! **WARNING - RISK OF CHILD DROWNING.** Extreme caution must be exercised to prevent unauthorized access by children. To avoid accidents, ensure that children cannot use a spa or hot tub unless they are supervised at all times.
- ! **DANGER** To reduce the risk of injury to persons, do not remove suction fittings.
- ▶ Spa location must accommodate sufficient drainage of water around the base of the structure, as well as the power source compartment.
- ▶ Prolonged immersion in water that is warmer than normal body temperature can result in a dangerous condition known as **HYPERTHERMIA**. The causes, symptoms, and effects of hyperthermia may be described as follows: Hyperthermia occurs when the internal temperature of the body reaches a level several degrees above the normal body temperature of 98.6°F. The symptoms of hyperthermia include dizziness, fainting, drowsiness, lethargy, and an increase in the internal temperature of the body. The effects of hyperthermia include (1) unawareness of impending hazard, (2) failure to perceive heat, (3) failure to recognize the need to exit spa, (4) physical inability to exit spa, (5) fetal damage in pregnant women, (6) unconsciousness resulting in danger of drowning. **WARNING** The use of alcohol, drugs or medication can greatly increase the risk of fatal hyperthermia in hot tubs and spas.
- ! **DANGER - RISK OF ELECTRICAL SHOCK.** Install at least 5 feet (1.5m) from all metal surfaces. (A spa may be installed within 5 feet of metal surfaces if each metal surface is permanently connected by a solid copper conductor attached to the wire connector on the terminal box that is provided for this purpose. Refer to NEC and local codes in effect at the time of installation.)
- ▶ A pressure wire connector is provided on the control box to permit connection of a solid copper bonding conductor between this point and any equipment, metal enclosures of electrical equipment, metal water pipe, or conduit within 5 feet (1.5m) of the unit as needed to comply with local requirements.
- ▶ Bond accessible metal to the dedicated connector on the equipment grounding bus, bond the equipment ground bus to the local common bonding grid as part of the installation in the form of (1) a reinforced concrete slab for support, (2) a ground plate provided beneath the hot tub or spa, or (3) a permanent ground connection that is acceptable to the local inspection authority.
- ! **DANGER RISK OF ELECTRICAL SHOCK.** Do not permit any electrical appliance, such as a light, telephone, radio, or television, within 5 feet (1.5m) of a spa or hot tub.

To reduce the risk of injury:

- ▶ The water in a spa or hot tub should never exceed 104°F (40°C). Water temperatures between 100°F (38°C) and 104°F (40°C) are considered safe for a healthy adult. Lower water temperatures are recommended for extended use (exceeding 10-15 minutes) and for young children.
- ▶ Excessive water temperatures have a high potential for causing fetal damage during the early months of pregnancy, pregnant or possibly pregnant women should limit spa or hot tub water temperatures to 100°F(38°C).

Before entering the spa or hot tub, the user should measure the water temperature with an accurate thermometer.

The use of alcohol, drugs, or medication before or during spa or hot tub use may lead to unconsciousness with the possibility of drowning.

Persons suffering from obesity or with a medical history of heart disease, low or high blood pressure, circulatory system problems, or diabetes should consult a physician before using a spa or hot tub.

Persons using medication should consult a physician before using a spa or hot tub since some medication may affect heart rate, blood pressure, and circulation.

For Units with a GFCI (Ground Fault Circuit Interrupter)

This appliance is provided with a ground-fault-circuit-interrupter located on the control box. Before each use and with the unit operating, push the test button. The unit should stop operating and the reset button should appear. Push the reset button. The unit should now operate normally. If the interrupter does not perform in this manner, a ground current is flowing indicating the possibility of electrical shock. Disconnect the power, or unplug from receptacle, until the fault has been identified and corrected.

For Cord and Plug Connected Units

Connected to a grounded, grounding type receptacle only. NEVER connect the spa to an extension cord.

Do not bury the cord.

WARNING To reduce the risk of electrical shock, replace damaged cord immediately.

For Permanently Installed Units

A terminal marked "G" or "ground" is provided in the wiring box located inside the equipment compartment. To reduce the risk of electric shock, connect the terminal or connector to the grounding terminal of your electrical service or supply panel with a continuous green insulated copper wire in accordance with National Electric Code Table 250-95 and any other local codes in effect at the time of the installation.

For Permanently Installed Units not Provided with an Internal Disconnecting Method

The electrical supply for this product must include a suitably rated switch or circuit breaker to open all ungrounded supply conductors to comply with Section 422-30 of the National Electric Code, ANSI/NFPA 70 1987. The disconnecting means must be readily accessible to the tub occupant but installed at least 5 feet (1.5m) from the tub water.

For Units with Gas Heaters

WARNING - Do not install indoors. This unit uses a gas heater that requires proper ventilation and is intended for outdoor use only.

For UL Listed Equipment Assemblies

Install at least 5 feet (1.5m) from tub water using nonmetallic plumbing. Install blower no less than 1 foot (305mm) above the maximum water level to prevent water from contacting electrical equipment. Install in accordance with the installation instructions.

To reduce the risk of drowning from hair and body entrapment, install a suction fitting(s) with a marked flow rate in gallons-per-minute that equals or exceeds the flow rate marked on the equipment assembly.

INTRODUCTION

Congratulations on your new purchase. This Equipment or Control System is constructed of the finest materials and assembled under the strictest quality control standards. With proper care and maintenance your system will provide you with many years of reliable performance.

The following pages contain information concerning the operation and care of your system.



Note: Your system may differ from the photos above although the basic operation and configuration will be the same.

FEATURES & FUNCTION

Your system comes equipped with features you should be aware of.

GROUND FAULT CIRCUIT INTERRUPTER (GFCI)

It is necessary to test the GFCI before each use and at least monthly when the spa or hot tub is not being used regularly.



Test the device in the following manner:

- With the power on, push the **"TEST"** button; there should be an audible "click", which will disconnect the power to the system. The **"RESET"** button will pop out slightly.

CAUTION - if the GFCI fails to operate in this manner, do not use the spa until a qualified technician has corrected the problem.

- To restore power, press the red **"RESET"** button in.



HEATER ON INDICATOR

All systems are equipped with a "Heater On" indicator to let the user know when the heater is actively heating the spa water.

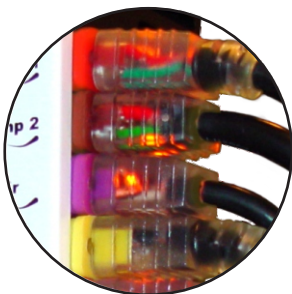

SMART CORDS

Your system may have come equipped with exclusive "Smart Cords". These cords have internal illumination to let you know that power is being supplied to the components connected to them. This is a helpful troubleshooting feature should a problem with a component arise.

YOUR SPASIDE CONTROL

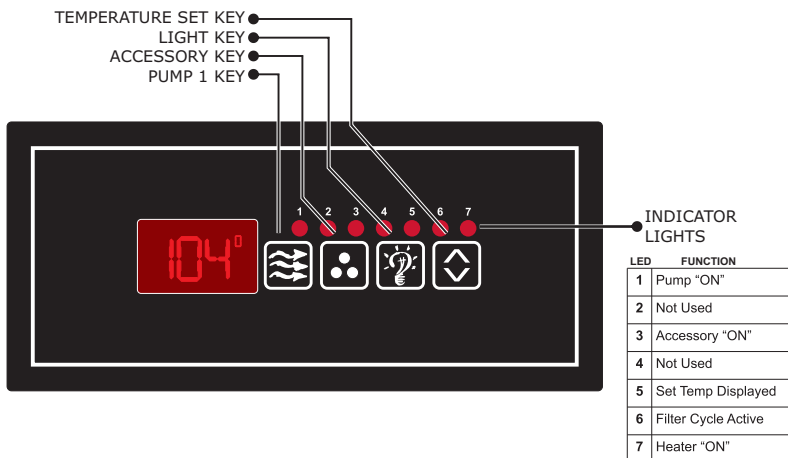

Default System Operation: When power is applied, or there is a temporary loss of power, the system will initiate its default programming. The filter cycle will begin 24-hours after the system has been powered up. The filtration cycle will be active for 1-hour and will repeat every 24-hours. The temperature will be maintained at 100°F.



Pump 1 Key: Press this key once to turn Pump 1 onto Low speed, press this key a second time to turn Pump 1 onto High speed, a third press will turn the pump off. A built-in timer will shut the pump off after 20 minutes of operation unless done so manually. The Pump 1 Indicator will illuminate while the pump is running. If the filter cycle indicator is illuminated, a filtration cycle has begun and you will not be able to turn the pump off.



Accessory Key: Press this key once to turn Accessory on and off. A built-in timer will shut the accessory off after 20 minutes of operation unless done so manually. The Accessory Indicator will illuminate while the pump is running.



Light Key: Press this key to turn the Light onto high intensity, a second press will turn the light to low and a third press will turn the light off. The light will automatically shut off after 2 hours.

SPASIDE CONTROL - Continued



Temperature Set Key: Press the Temperature Set key to decrease the desired temperature. Release and press again to lower the temperature. The temperature can be adjusted in 1°F increments from 59°F to 104°F (15°C to 40°C). The new setting will remain on the display for 5 seconds as a confirmation. During this time the Temperature Program indicator will illuminate to let you know this is the desired and not the actual temperature. After 5 seconds the display will return to the current temperature reading. When the temperature drops to 1°F below the set temperature, the heater will be turned on until the temperature is 1°F above the set temperature. The Heater On indicator will illuminate while the heater is on and flash when there is a call for heat and the heater has not yet been activated.

HEATER OPERATION

Your control system **may** have a convertible heater (120 volts; or 240 volts). Refer to the system data label to determine which, if any, convertible options are available to you. The heater configuration was set at the factory and may have been changed by your installer.

A covered, 300-gallon spa will experience a heat rise approximately as detailed below.

Your system will operate with one of the following configurations:

120 Volts - The heater will operate on demand during low speed pump operation. It will automatically shut off when the high-speed pump or blower is activated. You can expect a heat rise of 1°F to 2°F per hour.

240 Volt - The heater will operate on demand during high and low speed pump operation. It will continue to operate when the blower is activated. You can expect a heat rise of 6°F to 8°F per hour.

PROGRAMMING FILTRATION

Programming Filter Cycles: You may choose to filter the spa 1, 2 or 3 times per day as required to keep the water clean and sanitary. Press and hold the Pump 1 Key. The current setting will be displayed as F1, 2 or 3. Press and hold the Temperature Set Key to increase or decrease the frequency of the filtration cycles per day. The filter cycle is now set. The cycles will repeat every 8, 12 or 24 hours within a 24-hour period **starting from the time programmed**. It is recommended to schedule the filtration cycles so they do not interfere with sleeping hours.

Programming Filter Cycle Duration: You may choose to filter your spa 0 - 8 hours per cycle as required to keep the water clean and sanitary. Press and hold the Light key for 5-seconds. The current duration of the filter cycle will be displayed as D0 -8. Press and hold the Temperature Set key to increase or decrease the duration of the filter cycle. The duration is now set. To start a filter cycle immediately, press the Light key while the duration setting is still displayed.

Note: If a key is not pressed within 5 seconds during programming, the system will revert back to the monitoring mode. If the Pump and/or light were turned on during the programming process, turn them off. The system will revert back to display the water temperature within 5 seconds.

ADDITIONAL FEATURES

Smart Winter Mode: If the system detects ambient conditions below a preset factory setting, the system will automatically activate the Smart Winter Mode for a period of **24 hours**. In this mode, if a pump has not been powered in the last 2 hours, the system will turn it on for one minute to prevent freezing. The Filter Mode light indicator will flash while the pump is running in this mode. **Note: If you notice the pump coming on every 2 hours. This is the most likely cause. This will continue for a 24-hour period. This is normal and is the systems protection against freezing.**

Over Temperature Protection: If the water temperature exceeds 112°F at the Temperature sensor OH will appear on the display and the heater as well as all other outputs will shut off. After the water has cooled down power to the spa must be cycled on then off to reset the system. If the spa water temperature does not seem to be elevated, the error indication may have been caused by poor water flow or electrical line interference (thunder storms, voltage surges, etc.). Simply reset and monitor the system.

Power-Up Detection: Upon first powering the system or if a power outage occurs, the display will flash until a key is pressed. This feature also lets the user know there has been a power failure.

ERROR INDICATION

To assist the user in identifying problems with the spa, the system will display an error message. These messages will be helpful when communicating with your local dealer or qualified technician if a problem should arise.



PRESSURE or FLOW SWITCH ACTIVATED - This error will be displayed only when the pump is not activated. Cycle the pump through Low & High speeds then off. If the error does not clear this is an indication that the pressure or flow switch is activated with no water flow.

Contact your local spa dealer



PRESSURE or FLOW SWITCH NOT ACTIVATED - This error will be displayed while the is pump running. Cycle the pump through Low & High speeds. If the error does not clear this is an indication that the pressure or flow switch has not activated although there is water flow.

Contact your local spa dealer



TEMPERATURE SENSOR MALFUNCTION - This error will occur when a problem with the temperature sensor exists. This error may also occur if the system is activated while the water temperature is below 35°F.

Contact your local spa dealer



OVERHEAT or HIGH-LIMIT PROTECTION - There are three(3) stages of over-temperature:

1 - The spa water has exceeded 112°F. The heater, pump and accessory will be deactivated until the water cools to 109°F. *Be sure to check the actual water temperature with an accurate thermometer.*



2 - The spa water has exceeded 119°F. The heater will deactivate while the pump and accessory will still operate. *The blower (if equipped) can be activated to help cool the water. **WATER MUST BE BELOW 119°F AND POWER MUST BE RESET TO CLEAR THE "HL" ERROR***

A dirty spa filter can also cause a restricted flow of water, be sure the filter is cleaned regularly and ensure all water shutoff valves are open.

If the system has been operating normally until now, the pump may be overheating the spa. Refer to "Programing Filtration" on page 8 and reduce the duration and/or number of cycles per day.

3 - If you've eliminated items 1 & 2 as problems, the high-limit sensor may have malfunctioned.

Contact your local spa service center.

SPA LIGHT

Your control may contain a high intensity, low voltage light to enhance nighttime use.

This illustration shows how and where to find the bulb for replacement. It also shows the mounted spa light with a replacement (colored) lens. Colored lenses will further the enhancement of the light. Simply snap on or off to change the mood of your spa.

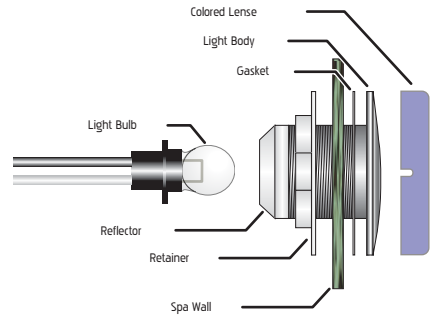

OPERATIONAL CONSIDERATIONS

The following describes situations you may encounter and situations to be aware of.

WARM WEATHER CONDITIONS

Since your spa will normally be expected to maintain warm to hot water to be ready for your use, a great deal of attention has been directed to the **energy conservation** detail of insulation so as to keep electrical costs down. This **energy conservation efficiency** may be achieved by extensive insulation of the skirt, plumbing and spa shell, and in some climates full foam insulation may have been provided.

This **energy conservation** feature may cause an inconvenience during warmer times of the year. During warm periods of the year, the temperature within the equipment compartment can elevate to a point that the pump will automatically turn off for a short period of time (15-30 minutes) to allow the pump to cool down before automatically restarting. This cool down feature will not harm your spa but serves only to protect the pump from damage and as an indicator that it is too hot. To minimize this occurrence, refrain from using your Hydrotherapy Jets for prolonged periods of time during warm seasons.

The jet pump chosen for your spa has been specifically sized for *maximum performance* and your Hydrotherapy enjoyment.

FILTRATION

Please refer to your Spa Manufacturer's owner's manual regarding the operation, maintenance and cleaning of your filtration system.

Dirty or clogged filters can cause flow restrictions and you may experience difficulty in reaching and/or maintaining desired heat levels.

FREEZE PROTECTION & WINTERIZING

When freezing weather and/or power losses are expected, contact your local spa dealer for freeze protection or winterizing recommendations for both the spa and the equipment system. Freeze related damage is not covered by the Hydro-Quip warranty.

CHEMICAL WATER TREATMENT

Your dealer is familiar with local water conditions and which chemicals are compatible with the water and are designed specifically for your spa. This is the best person to advise you on proper water quality management.

The one thing you can do to insure years of trouble free equipment operation is to maintain proper water chemistry.

Two basic goals of the chemical water treatment are sanitizing and balancing the water.

Sanitizing simply means keeping the water free from living microorganisms including algae, bacteria and viruses. The current most popular chemicals for sanitizing include chlorine, bromine and ozone.

Balancing water means establishing a balance among pH, total alkalinity and total hardness. Water that is unbalanced can corrode the spa and it's support equipment or leave deposits of minerals. Properly balanced water is essential to allow the sanitizing chemical to work effectively. There are numerous chemical additives to help you in controlling pH, total hardness and total alkalinity. **NEVER** use softened water when filling your spa. Softened water is extremely corrosive to the metal parts of the spa equipment and may lead to an unforeseen failure.

Sometimes, despite your most diligent efforts, your water may become too far out of balance to be managed chemically. At this point it is probably better to drain and clean the spa and start over with fresh water.

Equipment failure caused by improper water chemistry will not be covered under warranty.

TROUBLESHOOTING

The following describes situations and possible solutions to common problems you may encounter as a spa owner.

NOTHING OPERATES

Main Breaker is OFF - *Set to On.*

Sub-Panel Breaker Off - *Set to On.*

Equipment GFCI Off - *Set to On.*

Power switch in Off position - *Set to On.*

Components not plugged in - *Plug in components.*

Power cord not plugged in - *Plug in power cord.*

Over or High Temperature Protection On - *Refer to Section 3*

NO, LOW OR SURGING WATER FLOW

Air Lock in Plumbing System - *"Bleed" the system.*

Restricted Flow - *Insure that the water shut-off valves are open and that suction fittings are not blocked by debris.*

Dirty Filter - *Clean or replace filter.*

Low Water Level - *Increase water level to recommended level.*

NO LOW SPEED PUMP OPERATION

Low Level Programming Incorrect - *Contact your local dealer.*

Over or High Temperature Protection On - *Press button to reset.*

Pump Not Plugged-In - *Plug in the Pump.*

NO JETS OR BLOWER OPERATION

Blower or Pump Not Plugged-In - *Plug in the Blower or Pump.*

Over or High Temperature Protection On - *Press button to reset.*

NO THERAPY JET OPERATION

Water Shut-Off Valves are Closed - *Open Shut-Off valves.*

Dirty Filter - *Clean or replace filter.*

Jets Not Properly Adjusted - *Adjust Jets properly.*

Diverter Valve Not Properly Adjusted - *Adjust diverter valve properly.*

Thermal Overload Tripping - *Check for restricted flow of water.*

Over or High Temperature Protection On - *Press button to reset.*

WATER LEAKS

Spa Overfilled - *Adjust water level.*

Too Many People in the Spa - *Adjust water level.*

Drain-Valve Left Open - *Close drain valve.*

Couplings or Unions Loose - *Tighten or contact your local dealer.*

Pump Seal Leaking - *Contact your local dealer.*

Plumbing / Connections Leaking - *Contact your local dealer.*

Water Leaking from Spaside Control - *Contact your local dealer.*

Water in Air Blower Plumbing - *Contact your local dealer.*

NO HEAT

Temperature Not Set Correctly - *Adjust Set Point.*

Over or High Temperature Protection On - *Press button to reset.*

Current Limiting On - *120V Systems will not heat if High Speed or Blower is on. Contact your local dealer.*

No Power - *Reset breaker at service panel.*

Low Water Flow - *Clean or Replace filter.*

Pressure Switch Not Adjusted Properly - *Contact a qualified technician.*

HIGH HEAT

Temperature Sensor Not in Dry-Well - *Place sensor in dry-well.*

Temperature Set Too High - *Adjust Set Point.*

High Ambient Temperature - *Remove spa cover.*

GFCI TRIPS OCCASIONALLY

Lightning or Electrical Storm, Power Surge, Extremely Humid Conditions, or Radio Frequency Interference - *Reset GFCI.*

NOTE: GFCI must be properly grounded and bonded.

GFCI TRIPS IMMEDIATELY

Defective Component - *Contact a qualified service technician or the factory for assistance.*

NO LIGHT OPERATION

Light Bulb Defective - *Replace bulb or contact your local dealer.*

Reflector has Fallen Off - *Replace deflector or contact your local dealer.*

Light Not Plugged-In - *Plug in the Light.*

SYSTEM DATA LABEL

The system data label is located on the control box. This label is very important and contains information you will need to establish your electrical service. The voltage and amperage ratings are shown on the bottom of the label. Product, Model, Serial and Code numbers are also shown on the label.

Note: This information will be necessary if you should ever have to request warranty or any other type of service.

 HYDROQUIP™ THE SMART CHOICE™ <small>Corona, CA 92880 www.hydroquip.com</small>	ORDER CODE: CS7100 - CS7500 MODEL: XXXXXXX-XXXXXXX CODE: XXXX-XXXX-XXX VOLTS: 120 240 AMPS: SEE RATINGS LABEL PRODUCT: HQXXXX
REFER TO NEC FOR BREAKER SIZING	

WARRANTY INFORMATION

To all original purchasers, **HYDROQUIP** warrants its products to be free from defects in material and workmanship for a period of one year from the date of purchase.

HYDROQUIP will repair or replace the part, which in our opinion, is defective.

This warranty excludes damage as a result of: normal wear, freezing, low voltage, chemical abuse, accident, negligence, alteration, improper installation, use or care.

To obtain warranty service, return defective products within the warranty period to **HYDROQUIP**.

Purchaser is responsible for removal or reinstallation labor, freight charges, or any other such costs incurred in obtaining warranty service.

HYDROQUIP assumes no responsibility for incidental or consequential damages. Some states do not allow the exclusion of incidental or consequential damages, so the above limitations and exclusions may not apply to you. This warranty gives you specific legal rights and you may also have other rights, which vary from state to state.

**THE SPA DEALER MAY PROVIDE A DIFFERENT WARRANTY,
CONTACT YOUR SPA DEALER FOR DETAILS**

NOTES

Use this section to jot down any information you may need at a later date.

Dealer: _____ **Date of Install:** _____

Contact: _____ **Phone:** _____

Address: _____

City: _____ **State:** ___ **Zip:** _____

Notes: _____



HYDROQUIPTM

510A N. Sheridan Street · Corona, CA 92880-2024

Email: info@hydroquip.com · Internet: <http://www.hydroquip.com/>

Telephone: 951.273.7575 · Fax: 800.332.7190